

Duotour



The most versatile revolving door

The Duotour is a 2-wing revolving door with spacious compartments that easily accommodate large objects such as shopping and luggage trolleys, stretchers and wheelchairs. It provides simple, bi-directional, straight-line access and has a high capacity throughput of people. The unique design of the Duotour turns an ordinary entrance into an environmentally friendly and attractive entrance.

Central door wings

All Duotours include central doors within the two-wing door set which can be used for emergency escape purposes or left open when the full environmental benefits of the revolving door are not required. The AC model uses break-out swing doors (see fig 1) to provide the maximum possible clear width and the AS version

has automatic sliding doors (see fig 2). This allows the Duotour to be used as a fully automatic revolving door, an automatic sliding entrance or to be left completely open as traffic flow or special circumstances dictate. All in all, the Duotour is without doubt the most versatile entrance money can buy.

Your **Entrance.** Our **Technology.**

Revolving advertising space

A Duotour incorporates two revolving triangular showcases, one at each end of the door set, that attract everyone's attention. The showcases can be used for displaying all kind of products or as an advertising space. This advertising space could even be rented out to provide a source of revenue.

Numerous application areas

The variety of configurations enables us to offer you a suitable high capacity entrance solution for almost any building. You will often find our Duotour in airports, hospitals, banks, hotels, supermarkets and many types of public buildings.

Climate control

A revolving door creates the optimum solution to separate the outside and the inside of your building. A Duotour is open for people to pass through, but always closed to all the dirt, noise and weather outside. In this way you create and maintain a comfortable climate in your building.

Cost savings

With a Duotour you will win floor space, because the space behind the Duotour can be used as well. In addition, you will save a lot of the energy that would be used on heating or cooling your building if you had a type of door that cannot be permanently 'closed'. By saving energy, you will save money. In many instances, a Duotour will pay for itself within a couple of years.

Safety features

At Boon Edam, we put safety first. Our products comply with all relevant safety standards and regulations.

User safety

The Duotour comes with an extensive number of safety features:

1. *Safety Rail Bent wall (SRB)*
Active safety rubber buffers to prevent persons and objects being trapped between the rotating door wing (leading edge) and the stationary bent wall (leading mullion).
2. *Safety Rail Turning wall (SRT)*
Active safety rubber buffers on the rotating door wings (leading edges). The Duotour will stop immediately when the buffers are activated.
3. *Safety Rail Door wing (SRD)*
Foot protection, the Duotour will stop immediately when this sensor is activated.
4. *Emergency stop*
When activated, it will immediately stop the Duotour.
5. *Speed control*
Limits the maximum rotation speed. The speed is factory set and depends on door diameter.
6. *Horizontal Boon Sensor (HBS slow and stop)*
These two sensors are safeguarding the area in front of the door wings and the showcases. If the door wing or showcase is nearing a person the door will first slow down and if the door comes even closer the door will stop.
In sliding door mode, the HBS slow will function as threshold safety. When the HBS slow is activated (in sliding door mode only) the sliding door will reopen again.
7. *End Buffer Sensor (EBS stationary and rotating)*
This sensor prevents people being hit by the rotating door wing when they are trying to enter the Duotour at the last moment.
8. *Showcase Boon Sensor (SBS)*
The end stile of the curved showcase, directly underneath the rotating rubber safety buffer (SRT), is provided with an infrared sensor. This sensor is safeguarding the area directly in front the end stiles of the showcases at floor level.
9. *Threshold Sensor (THS, optional)*
This sensor is placed in the ceiling directly above the sliding door and protects the throat opening of the sliding door as well. When the THS is activated (in sliding door mode only) the sliding door will reopen again.
10. *Side Wing Sensor (SWS, optional)*
The movement area of the sliding door is protected by a special sensor, which gives an acoustic signal to advise people who are standing between the back edge of the sliding door and the stationary bent wall. This prevents accidents caused by the moving sliding door (in sliding door mode only).



Emergency escape with monitored battery back up

An emergency escape is provided via the central sliding doors. In the event of an emergency the door set will automatically move to the escape position and the centre doors will slide open, even if the main power fails (see fig 3). Unlike conventional revolving doors, the lack of centre column means that a totally clear opening is provided. This facility can also be used to provide automatic venting for smoke clearance where required.

Night security

The Duotour is provided as standard with electrical magnetic brake units. Parking the door set with the showcases closing off the entrance and activation of the brake units provides night security. There is no need for additional security doors (see fig 4).



*'The Duotour is without doubt
the most versatile entrance money can buy'*

Flexible design

The Duotour has many options in design and surface finish and can be manufactured to match or complement a wide variety of interiors and facades.

Finishing

The frame and door set can be finished in powder coated or anodised aluminium. The Duotour can be clad with stainless steel, bronze, brass or other metals (with exception of diameters >4800 mm).

Construction

The curved walls are available in either solid or glazed versions. Solid walls are constructed from aluminium sandwich panels. Glass walls provide a spacious and transparent feel and consist of slim line aluminium sections with laminated glass. The door set is constructed from extruded aluminium sections, horsehair weather-strips around the edges and tempered safety glass. The canopy can have plywood, stainless steel or aluminium dustcovers. A waterproof membrane can be applied for external use if required. The ceiling consists of folded panels, supplied with insulating material.

Options

- Glass protection sheets for trolleys
- Ceiling lighting with halogen or low energy lamps
- Push-button for the disabled (temporary low speed)
- Watertight roof
- OmniVent C or V (air curtains)

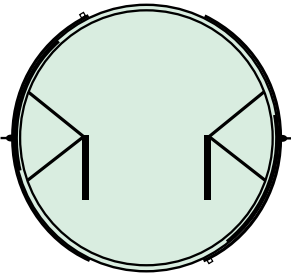

Fig 1

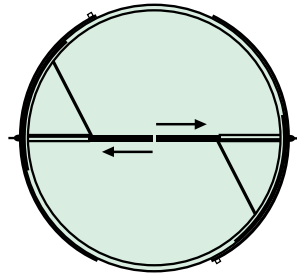

Fig 2

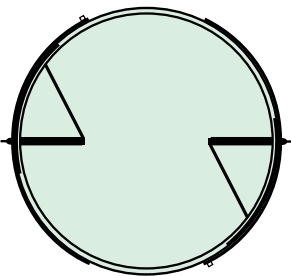

Fig 3

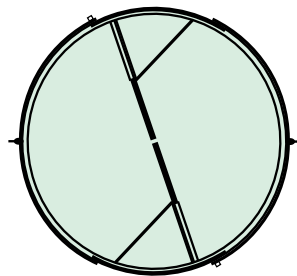

Fig 4

Standard dimensions and theoretical capacity

D Diameter (mm)	C Throat opening (mm)	E Installation width (mm)	F Doors width (mm)	Max. persons / segment	Capacity / minute ³	Type of traffic	Escape route	Disabled access
3600	1662	3804	1440 ¹ / 1640 ²	5	2 x 40			
4200	1962	4404	1740 ¹ / 1940 ²	7	2 x 48			
4800	2262	5004	2040 ¹ / 2240 ²	9	2 x 54			
5400	2562	5604	2340 ¹	11	2 x 59			

AS model (sliding door) and AC model (break-out swing door)

¹Sliding doors width

²Swing doors width

³Maximum capacity per minute indicates how many people can pass through the Duotour in both directions

Dimensions

Diameter	Height A (mm)	Height B (mm)
3600-4800	300-600	2200-2600
5400	400-600	2200-2300

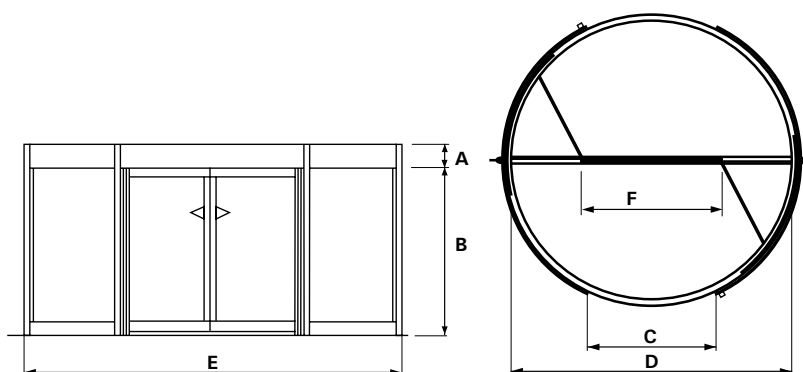

Technical specifications

Power supply	200-240 VAC, 50/60 Hz
Motor	AC motor, 3-phase
Power consumption:	
Drive units	800 W
Lighting	280 W (halogen) 98 W (low energy)
Ambient temperature	-20 °C tot +50 °C
Fuse	External power supply fused with 16 A slow

High quality

At Boon Edam, we take quality seriously. Quality of the materials we use, quality of our employees as well as quality of our partners. As with all Boon Edam products, the Duotour is manufactured to the highest standards, is CE approved and complies with the Machine Directive (98/37/EEC), the EMC-Directive (89/336/EEC) and the Low Voltage Directive (93/68/EEC).

Many Boon Edam revolving doors meet the requirements of the Dutch Council of the Chronically ill and the Disabled as being accessible for disabled people.



Distributor

Boon Edam B.V.
P.O. Box 40, 1135 ZG Edam
The Netherlands
T +31 (0)299 38 08 08 E sales@boonedam.nl
F +31 (0)299 37 28 59 I www.boonedam.com

 **BOON EDAM**
Door Systems

DT-0509-GBR-95903132